

PWMA Standard

**STANDARD FOR TESTING AND RATING
PERFORMANCE OF PRESSURE WASHERS:
DETERMINATION OF PRESSURE AND
WATER FLOW**

Pressure Washer Manufacturers' Association

Sponsor:



1300 Sumner Avenue
Cleveland, Ohio 44115-2851
www.pwma.org

PWMA PW101-2010 (Reaffirmed 2016)

**PRESSURE WASHER MANUFACTURERS' ASSOCIATION
Standard for Testing and Rating Performance of Pressure Washers:
Determination of Pressure and Water Flow**

Sponsor

Pressure Washer Manufacturers' Association

A Pressure Washer Manufacturers' Association (PWMA) standard is intended as a guide to aid the manufacturer, the consumer, and the general public. The existence of a PWMA standard does not in any respect preclude anyone, whether he has approved the standard or not, from manufacturing, marketing, purchasing or using products, processes, or procedures not conforming to the standard. Pressure Washer Manufacturers' Association standards are subject to periodic review and users are cautioned to obtain the latest editions.

CAUTION NOTICE:

This Pressure Washer Manufacturers' Association standard may be revised or withdrawn at any time. The procedures of the PWMA require that action be taken to reaffirm, revise, or withdraw this standard no later than five years from the date of publication. Purchasers of PWMA standards may receive current information on all standards by calling or writing the Pressure Washer Manufacturers' Association.

Sponsored and published by:
PRESSURE WASHER MANUFACTURERS' ASSOCIATION
1300 Sumner Avenue
Cleveland, OH 44115-2851
Phn: 216/241-7333
Fax: 216/241-0105
E-Mail: pwma@pwma.org
URL: www.pwma.org

Copyright © 2016 by Pressure Washer Manufacturers' Association
All Rights Reserved

No part of this publication may be reproduced in any form, in an electronic retrieval system or otherwise, without the prior written permission of the publisher.

Suggestions for improvement of this standard will be welcome. They should be sent to the Pressure Washer Manufacturers' Association.

Printed in the United States of America

CONTENTS

PAGE

Foreword	v
1. Purpose	1
2. Scope	1
3. Definitions	1
4. Documentation	2
5. Test Equipment.....	3
6. Test Procedures	3
7. Rating/Labeling	4
8. References	4

FIGURES

1. Figure 1.....	5
2. Figure 2.....	6

Foreword (This foreword is included for information only and is not part of PWMA PW101-2010 (Reaffirmed 2016), *Standard for Testing and Rating Performance of Pressure Washers: Determination of Pressure and Water Flow.*)

The following standard has been developed by the Technical Committee of the Pressure Washer Manufacturers' Association (PWMA) as an assistance and guide to the manufacturers, purchasers, and users of pressure washers. It is intended to provide a uniform method for testing and rating the performance of pressure washers with respect to pressure and water flow.

This standard is intended to apply to all products manufactured after September 30, 2011. The first standard was published as PW101-1998, with subsequent revisions in 1999, 2000, 2008 and 2010. The PWMA Technical Committee reaffirmed the standard in 2016.

PWMA recognizes the need to periodically review and update this standard. Suggestions for improvement should be forwarded to the Pressure Washer Manufacturers' Association, 1300 Sumner Avenue, Cleveland, Ohio, 44115-2851. All constructive suggestions for expansion and revision of this standard are welcome.

The existence of a Pressure Washer Manufacturers' Association standard does not in any respect preclude any member or non-member from manufacturing or selling products not conforming to this standard nor is the PWMA responsible for its use.

PWMA STANDARD

PW101-2010 (Reaffirmed 2016)

Standard for Testing and Rating Performance of Pressure Washers: Determination of Pressure and Water Flow

1.0 PURPOSE

The purpose of this standard is to provide a uniform method for testing and rating the primary performance characteristics of pressure washers that produce high pressure water.

2.0 SCOPE

This standard applies to pressure washers intended for the household, farm, consumer, or commercial/industrial markets. The pressure washers covered by this standard are portable, engine or electric motor driven, in which the discharge line is hand supported and manipulated.

3.0 DEFINITIONS

3.1 Break in: A required period of unit operation prior to conducting a maximum pressure and flow rate test.

3.2 Bypass: Condition under which trigger is released and the pump is re-circulating water internally.

3.3 Chemical injector: Device used to introduce chemicals into the water stream.

3.4 Engine: An internal combustion device that converts fuel into mechanical force or motion.

3.5 Engineering test unit: A non-production unit built to establish ratings.

3.6 Governed rpm: Engine regulated rpm.

3.7 Gpm: Gallons per minute

3.8 Loaded rpm: For engine driven units, the governed rpm while spraying water at system-rated conditions.

3.9 Maximum pressure: Pressure measured in the high pressure manifold area, upstream of any regulating or chemical injection devices, while the unit is operated at the set water flow condition.

3.10 Nozzle: A device with an orifice of known size, typically located at the end of the gun/wand assembly.

3.11 Pressure washer: A powered device, intended and designed for cleaning, that produces high pressure water at a minimum pressure of 500 psi and minimum flow of 1 gpm.

3.12 Psi: Pounds per square inch

3.13 Rpm: Revolutions per minute

3.14 Unloader: Device used to regulate or limit pressure.

3.15 Water flow: Water flow measured at either the inlet side of the pump or downstream of the pump while the unit is operated at the system rated conditions.

4.0 DOCUMENTATION

4.1 For products with internal combustion engines, the following information shall be provided for each model tested:

- 4.1.1 Testing conducted by _____ of _____
- 4.1.2 Date of test: _____
- 4.1.3 Name of product OEM: _____
- 4.1.4 Model number/name/type: _____
- 4.1.5 Rated maximum pressure (psi): _____
- 4.1.6 Rated water flow (gpm): _____
- 4.1.7 Name of pump manufacturer: _____
- 4.1.8 Pump model number: _____
- 4.1.9 Name of engine manufacturer: _____
- 4.1.10 Engine model number/name/type: _____
- 4.1.11 Label engine horsepower: _____
- 4.1.12 Design engine rpm: _____ at rated psi and gpm
- 4.1.13 Name of nozzle manufacturer: _____
- 4.1.14 Nozzle size: _____
- 4.1.15 Chemical injection system: Yes ___ No ___ If yes, orifice size: _____
Adjustable or fixed type? _____
- 4.1.16 Unloader: Adjustable or fixed type _____ Flow actuated or pressure actuated? _____

4.2 For products with electric motors, the following information shall be provided for each model tested:

- 4.2.1 Testing conducted by _____ of _____
- 4.2.2 Date of test: _____
- 4.2.3 Name of product OEM: _____
- 4.2.4 Model number/name/type: _____
- 4.2.5 Rated maximum pressure (psi): _____
- 4.2.6 Rated water flow (gpm): _____
- 4.2.7 Rated amps: _____
- 4.2.8 Rated voltage: _____ Frequency: _____
- 4.2.9 Name of pump manufacturer: _____
- 4.2.10 Pump model number: _____
- 4.2.11 Name of nozzle manufacturer: _____
- 4.2.12 Nozzle size: _____
- 4.2.13 Chemical injection system: Yes ___ No ___ If yes, orifice size: _____
Adjustable or fixed type? _____
- 4.2.14 Unloader: Adjustable or fixed type _____ Flow actuated or pressure actuated? _____

5.0 TEST EQUIPMENT

5.1 Calibration

5.1.1 Measuring instruments shall be calibrated over the range encountered during test against measuring instruments with a calibration that is traceable to National Institute of Standards & Technology (NIST) or other international measurement standard recognized by NIST.

5.1.2 The last date of calibration shall be clearly marked on each measuring device.

5.1.3 Measuring devices shall have been annually calibrated.

5.2 Instrumentation

5.2.1 The manufacturer name and model number for all test equipment (measuring devices) shall be recorded. The following test equipment shall be used:

5.2.1.1 Pressure measurement device capable of measuring average readings within +/- 1% of actual.

5.2.1.2 Flow measurement device capable of measuring average readings within +/- 1% of actual.

5.2.1.3 Rpm sensor capable of measuring within +/- 1% of actual.

5.2.1.4 Ammeter capable of measuring within +/- 1% of actual.

5.2.1.5 Voltmeter capable of measuring within +/- 1% of actual.

6.0 TEST PROCEDURES

6.1 Prepare unit(s) for test (See Figure 1).

6.1.1 Units shall be tested after break in and with production hose, gun, wand, and nozzle as intended for sale.

6.1.2 Units shall be broken in by running for a minimum of two (2) hours and a maximum of five (5) hours prior to test. During break in, units shall be running and shall be cycled on and off two times a minute (20 seconds in spray mode and 10 seconds in non-spray mode). For engine driven units, change oil after break in before conducting test.

6.1.3 Units shall be tested at factory settings or, for units that are intended to be adjusted by users, at the maximum setting that can be achieved by the user as noted in the manual.

6.1.4 When testing production units for compliance to this standard, considering manufacturing tolerances of the engine or electric motor, pump assembly, nozzle, etc., performance shall be a minimum of 90% of rated psi and gpm for both gas and electric units.

6.2 Pressure measurements shall be taken in the high pressure manifold area, upstream of any regulating or chemical injection devices. Unit shall be operating at the set water flow conditions (per 6.8) when taking water pressure measurements at the same time.

6.3 Flow measurement shall be taken either at the inlet side of pump or downstream of pump. Distance shall be determined using good engineering practices and the requirements of the measuring device. Unit shall be operating at system rated pressure conditions (if adjustable) when taking flow measurements at the same time.

6.4 For engine driven units, attach rpm sensor to engine.

6.5 For units driven by electric motors, monitor voltage and amperage. Amperage may vary per section 81.1 of UL 1776, *High Pressure Cleaning Machines*, 1995, or latest edition.

6.6 For units driven by electric motors, determine performance rating by controlling loaded (running) voltage at 120V \pm 1 volt at the source with the power cord attached to the motor as required by

section 16.1 of UL 1776, *High Pressure Cleaning Machines*, 1995, or latest edition.

6.7 Electric units shall be operating at the set pressure condition when taking pressure and flow measurements at the same time. Total stop, trapped, or spike pressure shall not be used when determining the ratings of the unit.

6.8 Water inlet pressure shall be 40 – 80 psig.

6.9 Attach device to measure water source temperature.

6.10 Ambient air temperature shall be 60 – 80°F.

6.11 Duration of test shall be 30 minutes of continuous operation; record readings every 5 minutes and calculate the average value. The average value shall be used to establish the unit performance and conformance to ratings.

6.12 Record observed readings and calculated average values on the appropriate test report form. Observed readings shall be taken to the nearest pound (psi) for pressure and the nearest one hundredth of a gallon (gpm) for flow and shall be in accordance with ASTM Practice E29 Rounding Off Method using significant digits in test data to determine conformance with specifications.

7.0 RATING/LABELING

7.1 Pressure washers shall be rated and marketed using Maximum Pressure and Water Flow Rate as determined using the test procedures outlined in this standard (Section 6.0).

7.2 Pressure and Water flow ratings shall be determined from maximum pressure and the operating flow test results average of at least 3 samples in accordance with Section 6 Test Procedures. Calculated values shall be taken to the nearest 1.0×10^{-1} for pressure and 1.0×10^{-2} for water flow. See Figure 2 for example.

7.3 Pressure ratings shall be in increments of 50 psi.

7.4 Water flow ratings shall be in increments of 0.1 gpm.

7.5 Pressure and Water flow ratings shall not be greater than the average of the three samples divided by 0.9 (allowable 10% tolerance).

7.5.1 Maximum Pressure example:
 $2307.2 \div 0.9 = 2563$ psi
Allowable rating: 2550 psi

7.5.2 Water Flow example:
 $2.11 \div 0.9 = 2.34$ psi
Allowable rating: 2.3 gpm

7.6 The pressure and flow rating shall be displayed on the product and packaging as a combination when tested concurrently with the production nozzle.

7.6.1 Example 1: 2600 psi at 2.3 gpm

Example 2: 2600 psi
2.3 gpm

Note: The word maximum may be inserted after or before the pressure or flow rating at the manufacturer's discretion.

7.7 The following statement may be used in reference to product which is tested and rated in accordance with this standard: "Water Flow and Maximum Pressure Ratings determined in accordance with PWMA Standard PW101 (latest edition)."

8.0 REFERENCES

UL 1776, *High Pressure Cleaning Machines*, 1995. Underwriters Laboratories. 333 Pfingsten Road, Northbrook, IL 60062.

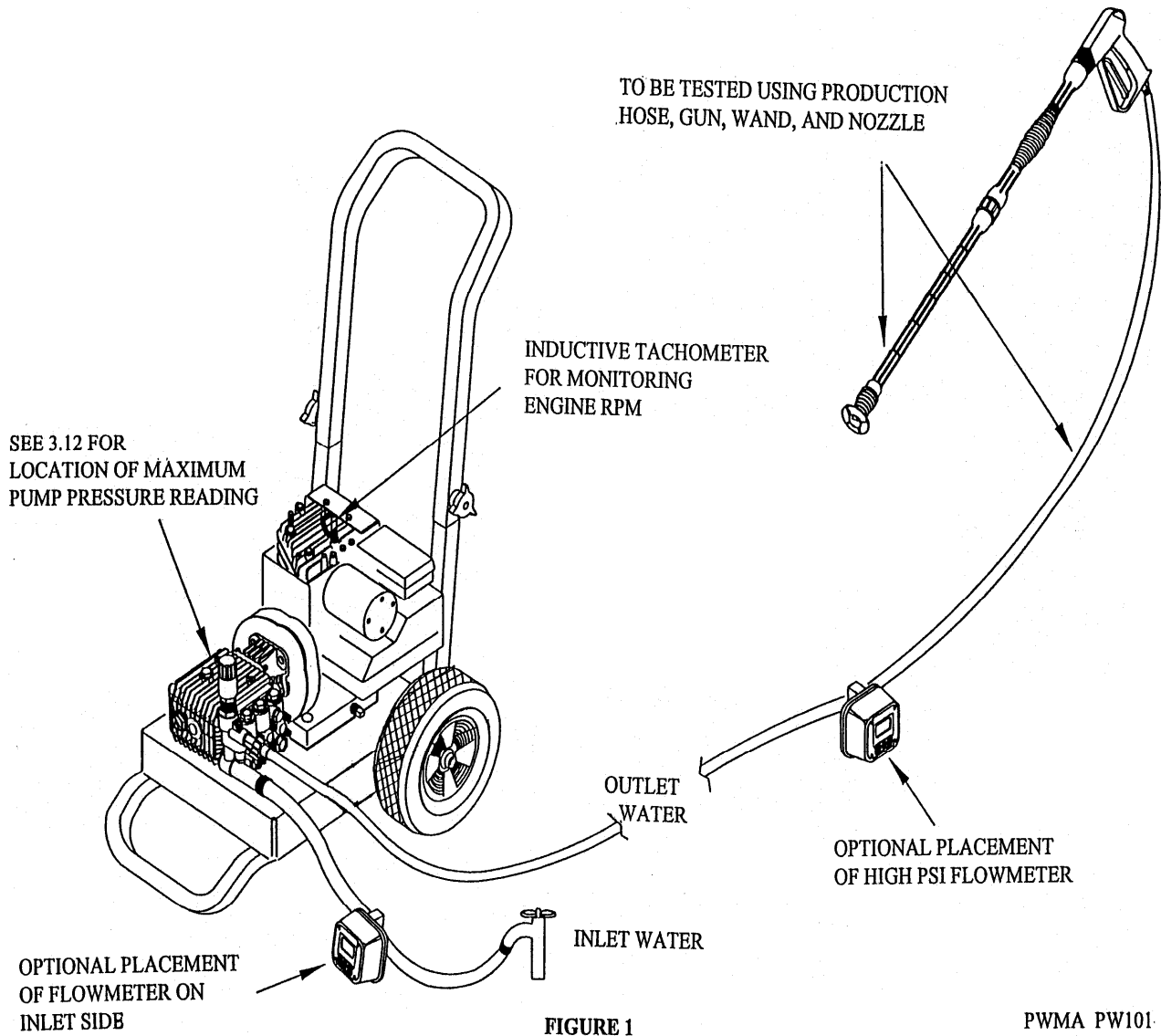

FIGURE 1

PWMA PW101

Example of Averaging and Rounding:

		Head Pressure (psi)	At Flow (gpm)
Sample 1	Test Observation 1	2310	2.09
	Test Observation 2	2330	2.12
	Test Observation 3	2290	2.11
	Test Observation 4	2320	2.13
	Test Observation 5	2310	2.1
	Test Observation 6	2290	2.11
Sample 2	Test Observation 1	2310	2.13
	Test Observation 2	2290	2.1
	Test Observation 3	2310	2.11
	Test Observation 4	2320	2.11
	Test Observation 5	2310	2.1
	Test Observation 6	2290	2.13
Sample 3	Test Observation 1	2340	2.13
	Test Observation 2	2280	2.09
	Test Observation 3	2310	2.13
	Test Observation 4	2310	2.11
	Test Observation 5	2330	2.09
	Test Observation 6	2280	2.11
Average (calculated value)		2307.2	2.11
Divided by 0.90 (calculated value)		2563	2.34
Maximum Allowable Rating		2550	2.3

Figure 2